

DETAILED PARTS AND ASSEMBLY PROCEDURE

LIST	PART No.	DESCRIPTION	Q'TY
1	EO Unit	Pulsarlube EO	N/A
2	NRV	Non Return Valve	N/A
3	B072	Protector for EO model oiler	N/A
4	A005	Reducer, 1/4" F x 1/8" M Adaptor	1
5	B002	Mounting Bracket, "L"Shape	1
6	B057	Washer	1
7	B051	Self Drilling Screw, #8 x 20	5
8	A012	Socket, 1/8" F x 1/8" F Adaptor	1
9	C007	Tube Fitting, Dia. 4mm x PT1/8" M	2
10	C010	Tube Clamp, Dia. 4mm x 1R	2
11	C021-1	Distribution Tubing, O.D. 4mm x I.D. 2.5mm Nylon Tubing, 10ft (3m)	1
12	C011	Insert, Dia. 4mm x 2.5mm	2
13	C009	Sleeve Ring, Dia. 4mm	2

NOTE : Oil brush and bracket assembly are available (Sold Separately).

ASSEMBLY PROCEDURE

1. Install the mounting bracket (5) at a proper location using screws (7) to allow for easy installation of the Pulsarlube EO.
2. Turn the lubricator upside down and fill with oil using a proper device. Avoid spilling oil on the outside of the lubricator.
3. Assemble the NRV (2) to lubricator tip.
4. Install unit vertically using the washer (6) and socket (8).
5. Connect a fitting connector (9) to the socket (8).
6. Connect each end of the tubing to a fitting connector (9). Assemble the insert (12) and sleeve ring (13) in order, as shown in the circled image on the left. (If an oil brush and bracket assembly are to be used, connect brush to a fitting connector (9) at the end of lube line using an appropriate socket).
7. Use the tube clamps (10) and screws (7) to affix the tubing (11) to a wall.
8. Install lubricator and follow lubricator operation instructions on user manual.

COMMENTS

1. Apply PTFE tape on all assembly points to prevent leakage.
2. Please check for compatibility between oil being used and plastic that lubricator is made of.
 - Synthetic Hydrocarbons, PAO : Compatible
 - Silicones (All Types) : Compatible
 - Fluorinated Esters : Compatible
 - Esters & Polyglycols : May cause a problem
3. Output volume may vary depending on oil viscosity, length of lube line, ambient temperature, etc.

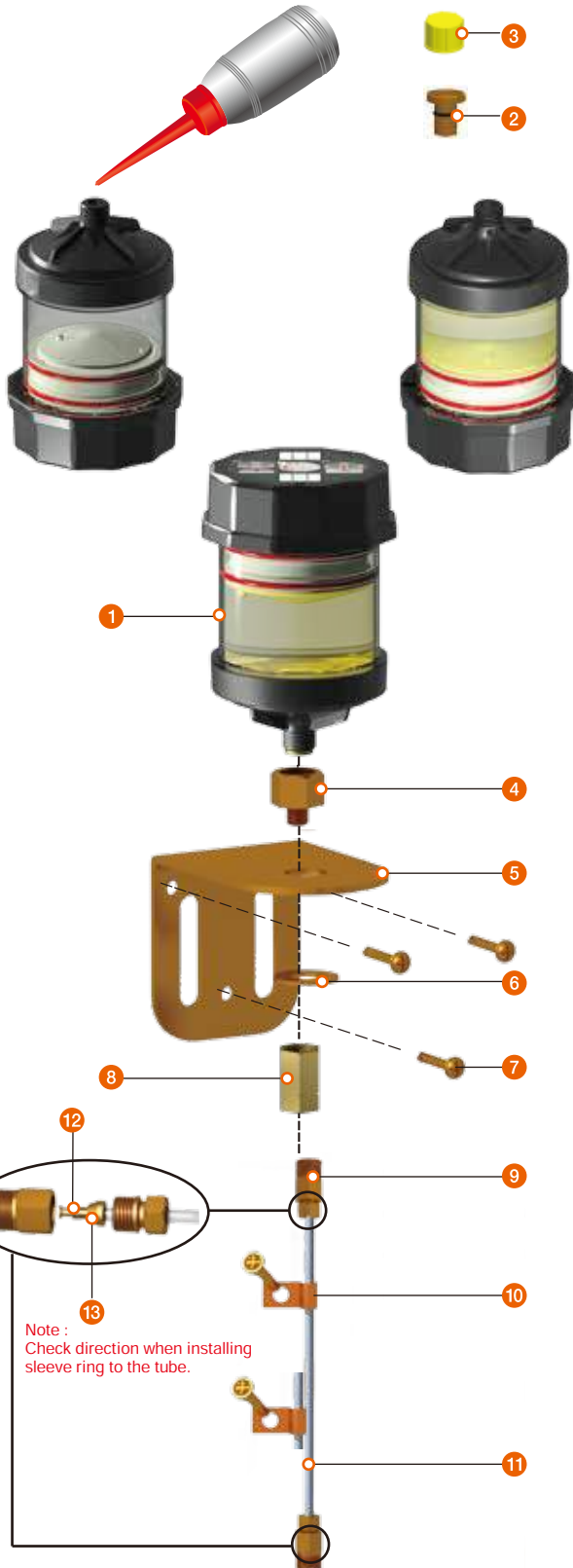

Note :
Check direction when installing
sleeve ring to the tube.

Note : All parts above are Metric thread.